

Mobil Altona Refinery Safety Case Overview



Mobil

Commitment to the Altona Refinery 2007 Safety Case

Mobil is committed to operating the Altona Refinery with concern for public safety in compliance with all local laws and meeting community expectations.

The Safety Case has been an opportunity for the refinery to critically examine all aspects of its operation. The Safety Case development process has enhanced the refinery's commitment to flawless operation.

The Safety Case assures the community that the refinery has the processes, equipment and professional people to operate safely and meet all statutory authority requirements.

The opportunities identified through the Safety Case development will enable the refinery to continue operating to very high standards of reliability, safety and environmental performance.

The refinery has significantly improved its safety performance over the past fifteen years and is approaching safety records that provide confidence that no person will get hurt in the conduct of its business. Over the past nine years, there have only been three Lost Time Injuries (LTIs) to employees or contractors working at the refinery, each in 2002, 2005 and 2007.

Due to the low number of LTIs, the refinery safety focus is on reducing the Total Recordable Injury Rate (TRIR). This includes LTIs and Medical Treatment Injuries (MTI's) per 200,000 work hours. TRIR per 200,000 work hours is represented in Figure 1 for the period 1999 – 2007.

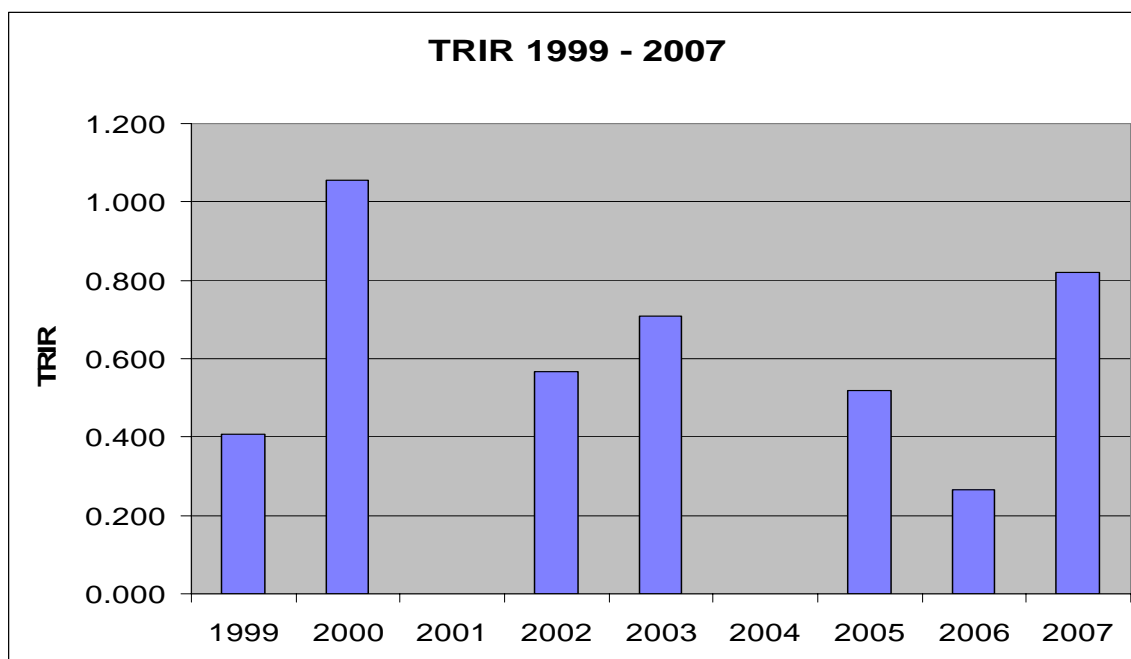

Figure 1: Total Recordable Injury Rate from 1999 – 2007

Table of Contents

COMMITMENT TO THE ALTONA REFINERY 2007 SAFETY CASE.....	2
FOREWORD	4
REFINERY OVERVIEW	6
THE OCCUPATIONAL HEALTH & SAFETY (MAJOR HAZARD FACILITY) REGULATIONS	8
ALTONA REFINERY'S SAFETY, HEALTH AND ENVIRONMENT POLICIES	9
INCIDENT PREPAREDNESS AND RESPONSE	11
SAFETY CASE SUMMARY.....	14
SAFETY ASSESSMENT AND SAFETY CONTROLS.....	15
OPERATIONS INTEGRITY MANAGEMENT SYSTEM.....	16
APPENDIX 1.....	11
ALTONA REFINERY - SIMPLIFIED PROCESS FLOW DIAGRAMS.....	11
APPENDIX 2.....	12
LOCALITY PLAN - REFINERY AREA.....	12
APPENDIX 3.....	13
LOCALITY PLAN - GELLIBRAND PIER AREA.....	13
GLOSSARY	20

Foreword

The purpose of this document is to provide information to the community regarding safety at Mobil Refining Australia Pty Ltds Altona Refinery, Blending Area, North Crude Tank Farm, South Crude Tank Farm, and Gellibrand Dock (Gellibrand Tank Farm). In doing so, this document aims to fulfil the requirements of the Occupational Health and Safety (Major Hazard Facilities) Regulations 2000 (the MHF Regulations) in relation to informing the community about the potential major incidents that could occur at the plant and any possible impact.

The Safety Case covers the three major hazard facilities, as defined by the MHF regulations, managed by the refinery:

- Mobil Altona Refinery Main Site - Corner Kororoit Creek and Millers Roads, Altona.
- South Crude Tank Farm - Kororoit Creek Road, Williamstown.
- Gellibrand Tank Farm - Nelson Parade, Williamstown.

The Safety Case was first submitted in 2002 and has since been updated to reflect improvements in the Safety Management System, the separation of the Mobil Yarraville Terminal from the Mobil Altona Refinery in 2004 and the implementation of the Altona Clean Fuels Venture (ACFV) and New Business Model (NBM) project in 2005. The ACFV changes were undertaken to meet new fuel quality specifications for sulphur and benzene in diesel and gasoline. The NBM changes were driven by a strategic objective to refocus the refinery to primarily supply the Victorian market.

In 2007 the Safety Case was resubmitted after revision of 17 units at the refinery. Updates to ACFV units were included in the 2005 Safety Case revision.

Should more information be required, or if there are any questions in relation to this document, please contact: -

Peter Dunster
Safety, Health and Environment Manager
Mobil Altona Refinery
Cnr Kororoit Creek and Millers Roads
PO Box 40
Altona 3018

PH (Direct): (03) 9286 5527
PH (Switch): (03) 9286 5666
FAX: (03) 9286 5596

Or

The Environmental Hotline provides contact 24 hours a day:

PH: 1800 659 527

Distribution and Custodianship

This is a controlled document owned by Mobil Refining Australia Pty Ltd

It is distributed as follows: -

1. Hobsons Bay Council
Corporate Centre
115 Civic Pde, Altona 3018
2. Williamstown Library
104 Ferguson St, Williamstown 3016
3. Altona Library
123 Queen St, Altona 3018
4. Newport Library
13 Mason St, Newport 3015
5. Worksafe Major Hazards Division
Level 24, 222 Exhibition St, Melbourne 3000

Refinery Overview

Overview

Mobil Altona Refinery currently produces about half of Victoria's petroleum fuel requirements from processing a combination of Gippsland Crude and various imported crude oils.

To accomplish this, the refinery has a core staff of over 300 people across a diverse range of functions.

History

- 1949** Refinery first came on stream as Standard Vacuum Oil Company. This was a joint venture between Standard Oil (Esso/Exxon) and Vacuum Oil Company (Mobil). Refinery produced lubricating oil and bitumen
- 1954** Refinery expanded to produce fuels after discovery of crude oil in New Guinea.
- 1962** Standard Vacuum Oil Company changed its name to Petroleum Refineries (Australia) Pty Ltd.
- 1970** Refinery expanded after discovery of Gippsland Crude oil in Bass Strait.
- 1991** Mobil bought out Esso's marketing and refining interests in Australia.
- 1997** Refinery decommissions the Thermoform Catalytic Cracker (TCC) and commissions the Fluidised Catalytic Cracker (FCC).
- 2000** Safety Case Outline submitted.
- 2002** Altona Refinery first Safety Case submitted and MHF licence awarded.
- 2005** Refinery implements a Clean Fuels project which includes a new Benzene Reduction Unit (BRU) to meet new clean fuels specifications for benzene limits in petrol and a revamped Catalytic Hydrodesulphurisation Unit (CHD) to produce diesel that meets the new 50 ppm sulphur limit.

Refinery implements a New Business Model (NBM) to streamline its operations and decommissions one crude train, one reforming unit and one pre-treating unit.
- 2006** Refinery begins supplying propane to Qenos and RGP (Refinery Grade Propylene) to Basell.
- 2007** Altona Refinery Safety Case Revision, submission and MHF unconditional licence renewed.
- 2007** 2nd MHF licence awarded.
- 2007-** Ongoing Oversight.
- 2012**

Products

Mobil Altona Refinery produces the products shown on the chart below.

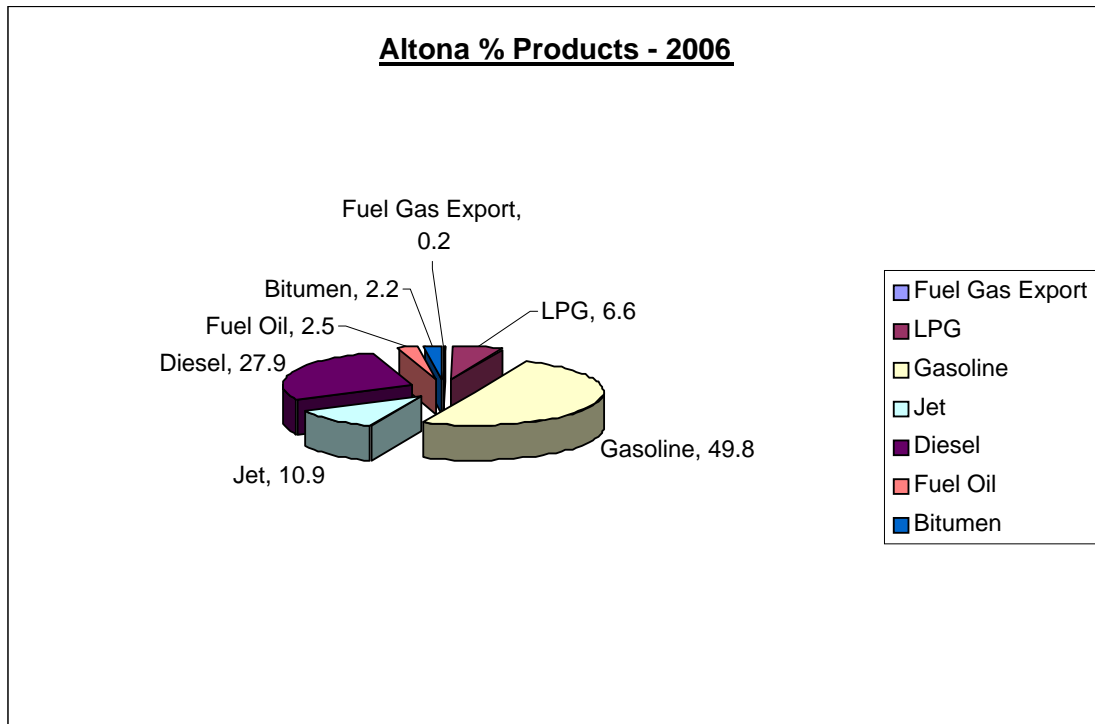

Processes

The processes used to manufacture these products are outlined below. The Refinery Process Flow Diagram and Site Layout Plans are shown in Appendix 1, 2 and 3.

Gippsland crude oil arrives via pipeline and is stored in tanks in the North Crude Tank Farm. Other crude oil arrives by ship to Gellibrand Pier where it is transferred by pipeline to the refinery.

The crude oil is heated in a gas-fired heater and distilled under pressure to produce intermediate and final products. Further chemical processing is done to maximise the amount of useful product produced. The refinery uses Fluidised Catalytic Cracking technology to turn low value intermediate product into liquefied petroleum gas (LPG), gasoline and diesel. Catalytic Reforming technology is used to produce high-octane blendstock used in the high performance fuels demanded by modern automobiles.

Intermediate products are stored in tanks in the Blending Area and South Crude Tank Farm.

Final product blending for fuels occurs in the Blending Area before transfer via pipeline to Mobil Yarraville, Somerton and other oil companies.

Liquefied petroleum gas (LPG) is produced, blended and stored at the refinery. LPG is then distributed to consumers by road tanker.

Bitumen is produced in the Cutback Bitumen Unit from kerosene / bitumen feedstock shipped into Altona Refinery. Bitumen is distributed off-site by road tanker.

Light gases are produced from various processes. These are collected and distributed around the Refinery as fuel gas, which is used to heat up process streams to the desired temperature.

The Occupational Health & Safety (Major Hazard Facility) Regulations

Purpose

The Victorian Occupational Health and Safety Regulations 2007 came into operation on 1 July 2007. These regulations can be obtained from the Worksafe website (www.workcover.vic.gov.au).

*The objective of these Regulations is to provide for the safe operation of **major hazard facilities** in order to:*

- (a) *Reduce the likelihood of a **major incident** occurring;*
- (b) *Reduce the consequences to health and safety and damage to property in the event of a major incident.*

The Altona Refinery is registered under these regulations as a Major Hazard Facility due to the volume of liquefied petroleum gas and flammable liquids stored and processed at the site.

Safety Case

Under the MHF Regulations the operator of an MHF must produce a Safety Case. A 'Safety Case' is a written document in which the operator of a major hazard site describes the measures in place to prevent a major incident and also how it would deal with a situation should such an incident occur.

The Safety Case must demonstrate that incident prevention and management measures are appropriate and adequate, and that risks have been controlled as far as practicable.

A Safety Case is written following a full examination of the facility's activities, the potential for major incidents and the risk control measures.

Scope

The Altona Refinery Safety Case covers the Altona Refinery / Blending Area, North Crude Tank Farm, South Crude Tank Farm, and Gellibrand Dock (Gellibrand Tank Farm).

Local Community

The MHF Regulations require Mobil Altona Refinery to inform the local community about the safety of its operations. Regulation 5.2.24 (Information to Local Community) of the Regulations outlines in detail the information to be provided. It is a requirement that a summary of the Altona Refinery Safety Case is available to the community. In addition to this document, information on the Safety Case Review has been presented to the Altona Refinery Community Liaison Committee (CLC) meetings in 2006 and 2007.

The Altona Refinery hosts a CLC for the sharing of information with the local community. This includes representatives from the Hobsons Bay City Council, EPA, local residents and the refinery. The CLC has been operating for over 13 years and meets quarterly to provide the community with a means of communicating with Mobil on Altona Refinery issues. In addition to meetings, a quarterly newsletter is also produced and distributed to the neighbourhood.

Altona Refinery's Safety, Health and Environment Policies

The Altona Refinery is wholly owned by Mobil Refining Australia Pty Ltd which is a subsidiary of Exxon Mobil Corporation, USA ("the Company")

Safety

It is the Policy of the Company and its affiliates to conduct business in a manner that protects the safety of employees, others involved in its operations, customers, and the public.

The Company and its affiliates will strive to prevent all accidents, injuries, and occupational illnesses through the active participation of every employee. The Company and its affiliates are committed to continuous efforts to identify and eliminate or manage safety risks associated with its activities.

Accordingly, the policy is to:

- design and maintain facilities, establish management systems, provide training and conduct operations in a manner that safeguards people and property;
- respond quickly, effectively, and with care to emergencies or accidents resulting from its operations, cooperating with industry organisations and authorised government agencies;
- comply with all applicable laws and regulations, and apply responsible standards where law and regulations do not exist;
- work with government agencies and others to develop responsible laws, regulations, and standards based on sound science and consideration of risk;
- conduct and support research to extend knowledge about the safety effects of its operations, promptly applying significant findings and, as appropriate, sharing them with employees, contractors, government agencies, and others who might be affected;
- stress to all employees, contractors, and others working in its behalf their responsibility and accountability for safe performance on the job and encourage safe behaviour off the job;
- undertake appropriate reviews and evaluations of its operations to measure progress and to ensure compliance with this policy.

Health

It is the Policy of the Company and its affiliates to:

- identify and evaluate health risks related to its operations that potentially affect its employees, contractors or the public;
- implement programs and appropriate protective measures to control such risks, including appropriate monitoring of its potentially affected employees;
- communicate in a reasonable manner to potentially affected individuals or organisations and the scientific community, knowledge about health risks gained from its health programs and related studies;
- determine at the time of employment and thereafter, as appropriate, the medical fitness of employees to do their work without undue risk to themselves or others;
- provide or arrange for medical services necessary for the treatment of employee occupational illness or injuries and for the handling of medical emergencies;
- comply with all applicable laws and regulations, and apply responsible standards where laws and regulations do not exist;
- work with government agencies and others to develop responsible laws, regulations and standards based on sound science and consideration of risk;
- conduct and support research to extend knowledge about the health effects of its operations;
- undertake appropriate reviews and evaluations of its operations to measure progress and to ensure compliance with this policy;
- provide voluntary health promotion programs designed to enhance employees' well being, productivity, and personal safety. These programs should supplement, but not interfere with, the responsibility of employees for their own health care or their relationship with personal physicians. Information about employees obtained through the implementation of these programs should be considered confidential and should not be revealed to non-medical personnel except: at the request of the employee concerned, when required by law, when dictated by overriding public health considerations, or when necessary to implement the guidelines of the Alcohol and Drug Use Policy.

Environment

It is the Policy of the Company and its affiliates to conduct business in a manner that is compatible with the balanced environmental and economic needs of the communities in which they operate.

The Company and its affiliates are committed to continuous efforts to improve environmental performance throughout its operations.

Accordingly, the policy is to:

- comply with all applicable environmental laws and regulations and apply responsible standards where laws and regulations do not exist;
- encourage concern and respect for the environment, emphasise every employee's responsibility in environmental performance and ensure appropriate operating practices and training;
- work with government and industry groups to foster timely development of effective environmental laws and regulations based on sound science and considering risks, costs and benefits, including effects on energy and product supply;
- manage its business with the goal of preventing incidents and of controlling emissions and wastes to below harmful levels; design, operate and maintain facilities to this end;
- respond quickly and effectively to incidents resulting from its operations, cooperating with industry organisations and authorised government agencies;
- conduct and support research to improve understanding of the impact of its business on the environment, to improve methods of environmental protection, and to enhance its capability to make operations and products compatible with the environment;
- communicate with the public on environmental matters and share its experience with others to facilitate improvements in industry performance;
- undertake appropriate reviews and evaluations of its operations to measure progress and to ensure compliance with this policy.

Product Safety

It is the Policy of the Company and its affiliates to:

- identify and manage risks associated with its products and not manufacture or sell products when it is not possible through proper design, procedures, and practices to provide an appropriate level of safety for people and the environment;
- specify precautions required in handling, transporting, using, and disposing of its products and take reasonable steps to communicate them to employees, customers, and others who might be affected;
- comply with all applicable laws and regulations and apply responsible standards where laws and regulations do not exist;
- work with government agencies and others, as appropriate, to develop responsible laws, regulations, and standards based on sound science and consideration of risk;
- include identification and control of potentially adverse health, safety, and environmental effects as priority considerations in the planning and development of products;
- conduct and support research to extend knowledge about the health, safety and environmental effects of its products, promptly applying significant findings and, as appropriate, sharing them with its employees, contractors, customers, the scientific community, government agencies, and the public;
- undertake appropriate reviews and evaluations of its operations to measure progress and to ensure compliance with this policy.

Incident Preparedness and Response

Overview

Mobil Altona Refinery is well prepared to handle foreseeable incidents. Critical to the refinery's response strategy are regular emergency response exercises, conducted in collaboration with the local council, Victoria Police and the Metropolitan Fire and Emergency Services Board (MFESB).

Potential Major Incidents

The MHF Regulations define a Major Incident as an uncontrolled incident, including an emission, loss of containment, escape, fire, explosion or release of energy, that (a) involves Schedule 9 materials (refer to Scheduled Materials table below); and (b) poses a serious and immediate risk to health and safety.

The potential Major Incidents captured under the MHF Regulations that have been identified at the refinery are extremely unlikely to have offsite consequences. The controls and training in place at the refinery ensure any potential for offsite consequence is minimised.

Potential hazards and their worst case consequences that may occur at the refinery are summarised in the table below:

Hazards	Magnitude of Major Incidents	Potential Consequences
Abnormal operating temperatures Elevated pressures	Potential Loss of Containment of large quantities of: <ul style="list-style-type: none"> – Flammable liquids or gases – Toxics 	Potential <u>onsite</u> impacts such as: <ul style="list-style-type: none"> – Fire and/or Explosion – Toxic / corrosive releases With potential for health & safety consequences such as fatalities, serious injuries or illnesses requiring medical treatment.
		Potential <u>offsite</u> impacts such as: <ul style="list-style-type: none"> – Injuries as a result of damage to windows and/or internal/external building damage from an explosion. Injuries sustained may require medical treatment. – Exposure to materials that may involve mild transient health effects (e.g. short term respiratory difficulty) that will not impair an individual to take protective actions. – Other impacts such as smoke, visible flaring, noise, and /or public disruption (actions by emergency services e.g. road closure or evacuation)

The types of materials that could potentially be involved in an incident at the Refinery are summarised in the table below:

Scheduled Materials	
Large Quantities	Smaller Quantities
Compressed and Liquefied Gases e.g. LPG	Oxidising Materials e.g. Hydrogen Peroxide solution
Flammable Materials e.g. Gasoline	Toxic Materials e.g. Hydrogen Sulphide (entrained in process streams)

Training

Incident preparedness and response training has been designed and implemented to equip all appropriate refinery personnel with the knowledge and skills required for appropriate initial response. A training schedule has been formulated to ensure effective implementation occurs across all areas of the refinery and includes:

- field exercises
- desktop exercises
- integrated exercises between field and management response teams
- an induction program
- trial emergency evacuations

To ensure the quality and currency of response plans, procedures and training, a comprehensive review and debrief of completed training and any actual emergency incidents is undertaken.

Equipment and Facilities

Equipment and facilities available on site at the refinery to be used in the event of an emergency include:

- communications equipment
- emergency control centre from which incident support is co-ordinated
- stationary and mobile fire suppression and control systems (eg. fire tenders, foam dispensing equipment and fire water systems)
- response vehicles
- ancillary equipment (eg. personal protective equipment)

To ensure that on site emergency response equipment and facilities are effective when called on for use, an on going program of inspection, testing, maintenance and replacement is in place.

Collaborative Arrangements

A key element in the successful response to a refinery emergency is the role of the MFESB. In acknowledgment of this, Mobil Altona Refinery has sought to build strong ties with MFESB; jointly undertaking integrated planning, training and information sharing.

The refinery also maintains relationships with other key organisations likely to be involved in an emergency response incident, such as Victoria Police, EPA, Melbourne Ports Corporation, Victorian Ambulance Service, WorkCover and Hobsons Bay City Council.

Resources are also available on a mutual aid basis from organisations such as Qenos.

Community Notification and Response

In the event of an incident occurring with offsite impact, the Victoria Police has responsibility for evacuation in consultation with the refinery and MFESB Incident Controller.

The police, if needed, will use the electronic media including commercial radio stations 3AW (693 AM), ABC (774 AM) and local community radio station Stereo 974 (97.4 FM) to broadcast information and advice to the community.

The refinery also uses "telephone trees" for early notification to key community contacts including members of the CLC, local schools and kindergartens.

The local council is kept informed of incidents and can provide information.

Community feedback on incident investigations is given as part of the Community Liaison Council (CLC) briefings.

Contact can also be made via the 24 hour Environmental Hotline.

Sirens at the Mobil Altona Refinery are sounded to alert on site personnel only. People in the community do not need to take action in response to the sounding of these sirens. In the case of emergency, Police and Emergency Services personnel will direct community members if any action is required.

Safety Case Summary

General

The Occupational Health and Safety Regulations 2007 requires operators of Major Hazard Facilities (MHF) to prepare a Safety Case. An MHF is defined as a facility with hazardous material above defined threshold quantities, detailed in Schedule 9 of the Regulations. The Mobil Altona Refinery was registered as an MHF and after preparing and submitting a Safety Case for all of the sites that it manages, was granted a five year unconditional licence. As part of the licence renewal process in 2007, after an extensive review, an updated Safety Case has been prepared and submitted to the Victorian WorkCover Authority (VWA).

The Safety Case demonstrates how the Mobil Altona Refinery is being managed to ensure that health and safety risks are reduced so far as is practicable and the potential damage to property or the environment is minimised. In order to achieve this, the following processes have been implemented:

- Identify all hazards that may lead to a potential major incident;
- Assess the likelihood and consequences of the potential major incident;
- Identify the controls in place to prevent and mitigate the potential major incident and identify any additional controls that can further reduce the risk so far as is practicable;
- Ensure that the Safety Management System (SMS) controls and monitors these risks; and
- Eliminate or reduce the health and safety risk so far as is practicable .

The Safety Case includes the following components:

1. **Facility Description**
2. **Safety Management System Description**
3. **Safety Assessment** - What the potential major incidents, risks and controls are
4. **Safety Controls** - Details the control measures and how their effectiveness is maintained
5. **Emergency Response** - Action taken in the event of a major incident

Offsite risks to nearby neighbours that could be impacted by a potential major incident are also examined in the Safety Case. Risks to nearby neighbours have been significantly reduced as part of Safety Case work.

In addition, the Mobil Altona Refinery Safety Case includes an assessment of the potential for other "coordinated MHF sites" to impact the safety of the Mobil Altona Refinery or any impact on those sites from the Mobil Altona Refinery.

The "coordinated sites" (nominated by WorkCover) are:

- Esso's Long Island Point facility, at Hastings;
- Elgas Ltd's Altona facility;
- Qenos Olefins Pty Ltd's Altona facility;
- Mobil Oil Australia Pty Ltd's Yarraville Terminal;
- Caltex Pty Ltd, Newport Terminal;
- The Shell Company of Australia Pty Ltd's Newport Terminal.

Safety Assessment and Safety Controls

The Safety Assessment demonstrates how potential major hazards are identified and associated risks assessed.

Facility modifications and changes to procedures are made where required to reduce risk so far as is practicable .

For example the role that procedures play in the process is shown in **Figure 1** below.

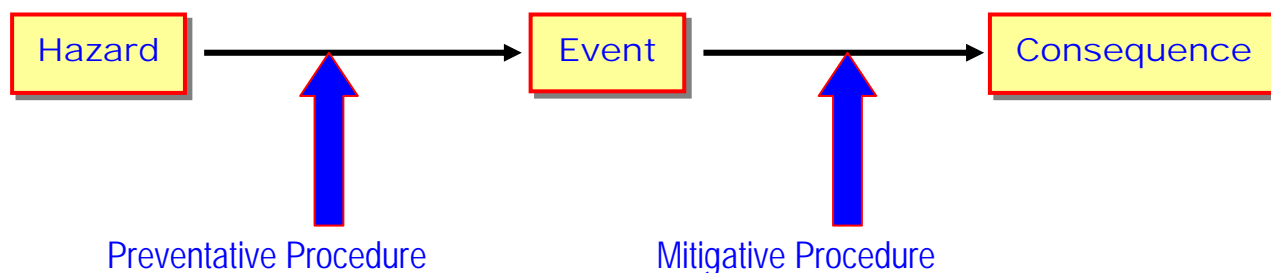

Fig. 1: Preventative and Mitigative Procedures

A preventative procedure is designed to stop a potential major incident from occurring. An example of a preventative procedure is a vessel isolation procedure that reduces so far as is practicable the likelihood of a loss of containment incident.

A mitigative procedure is designed to reduce the severity of the consequences. An example of a mitigative procedure would be an emergency response procedure that minimises the severity of the incident by ensuring appropriate and timely responses.

A hazard is a potential physical or chemical process, procedure or circumstance which could result in a potential Major Incident.

An event is an occurrence related to equipment performance or human action, or an occurrence external to the system that causes a system upset. In this document, an event is either the cause of or a contributor to an incident or accident, or is a response to an accident's initiating event.

A consequence is the outcome of an event or incident expressed qualitatively or quantitatively, being loss, injury, disadvantage or gain.

Operations Integrity Management System

The Altona Refinery uses the ExxonMobil Operations Integrity Management System (OIMS) as its Safety Management System at the site.

ExxonMobil's approach to managing its operations in a manner which is sensitive to safety, health, and the environment (SH&E) is embedded in OIMS.

OIMS conforms to all requirements of AS/NZS ISO 9002: *Quality Systems - Model for quality assurance in production, installation and servicing*.

OIMS is used both to ensure compliance with laws and regulations and to drive SH&E improvements of a non-regulatory nature sought by management.

OIMS consists of 11 primary elements.

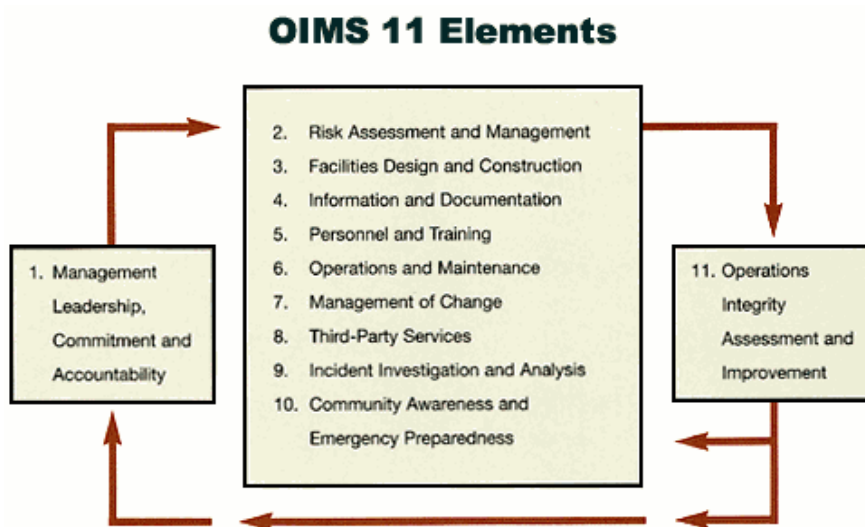

Within these elements, ExxonMobil has specified over 60 expectations regarding the standards and practices for a refinery. To meet these OIMS expectations, the Mobil Altona Refinery has developed 21 systems.

21 systems support OIMS at the refinery and focus on:

Management Commitment

Processes to achieve common and sustainable SH&E management processes and leadership.

Regulatory Compliance

Processes by which regulatory compliance is achieved.

Personnel

Processes for employee selection, personnel changes, placement and ongoing assessment.

Training

The identification of individual training needs and the development of programs to satisfy these.

Community Awareness

Processes for ensuring effective community consultation and interaction.

Operations Interface Management

Processes for the identification and assessment of all interfaces with other ExxonMobil or third party assets.

Incident Investigation

Incident reporting and investigation processes.

Environmental Protection

The management and minimisation of wastes and emissions, and processes for environmental improvement.

Occupational Health

Processes for the management of occupational health risks.

Third Party Selection and Evaluation

Ensuring that contractors are aligned with the Refinery's SH&E standards and work to them.

Personnel Safety

The processes to ensure safe work practices.

Work Permit

The proactive identification and management of potential hazards prior to the commencement of work.

Information and Documentation

Processes to ensure employees and others have access to engineering drawings and other information regarding refinery unit operation, capabilities and potential SH&E hazards.

Operations and Maintenance Procedures

Processes to ensure operations are within defined operational and regulatory limits. Includes Operating and Maintenance Procedures, Operating Limits, Shift Hand Over, Alarm Management, Internal Interfaces and Site Security.

Mechanical Integrity

Processes for the inspection and reliability of refinery fixed and rotating equipment.

Critical Equipment

Processes for the identification, testing and periodic maintenance of refinery critical safety equipment.

Management of Change

The process to manage changes and provides a structure for understanding the effects of change.

Risk Management

The identification and management of potential hazards.

Emergency Response

The playing-out of potential emergency scenarios and capability testing of equipment and personnel.

OIMS Assessment and Improvement

The processes and assessment requirements to achieve continuous OIMS improvement.

Facilities Design and Construction

The process for identification, assessment and reduction of risks throughout the facilities design and construction phase.

Appendix 1

Altona Refinery - Simplified Process Flow Diagrams

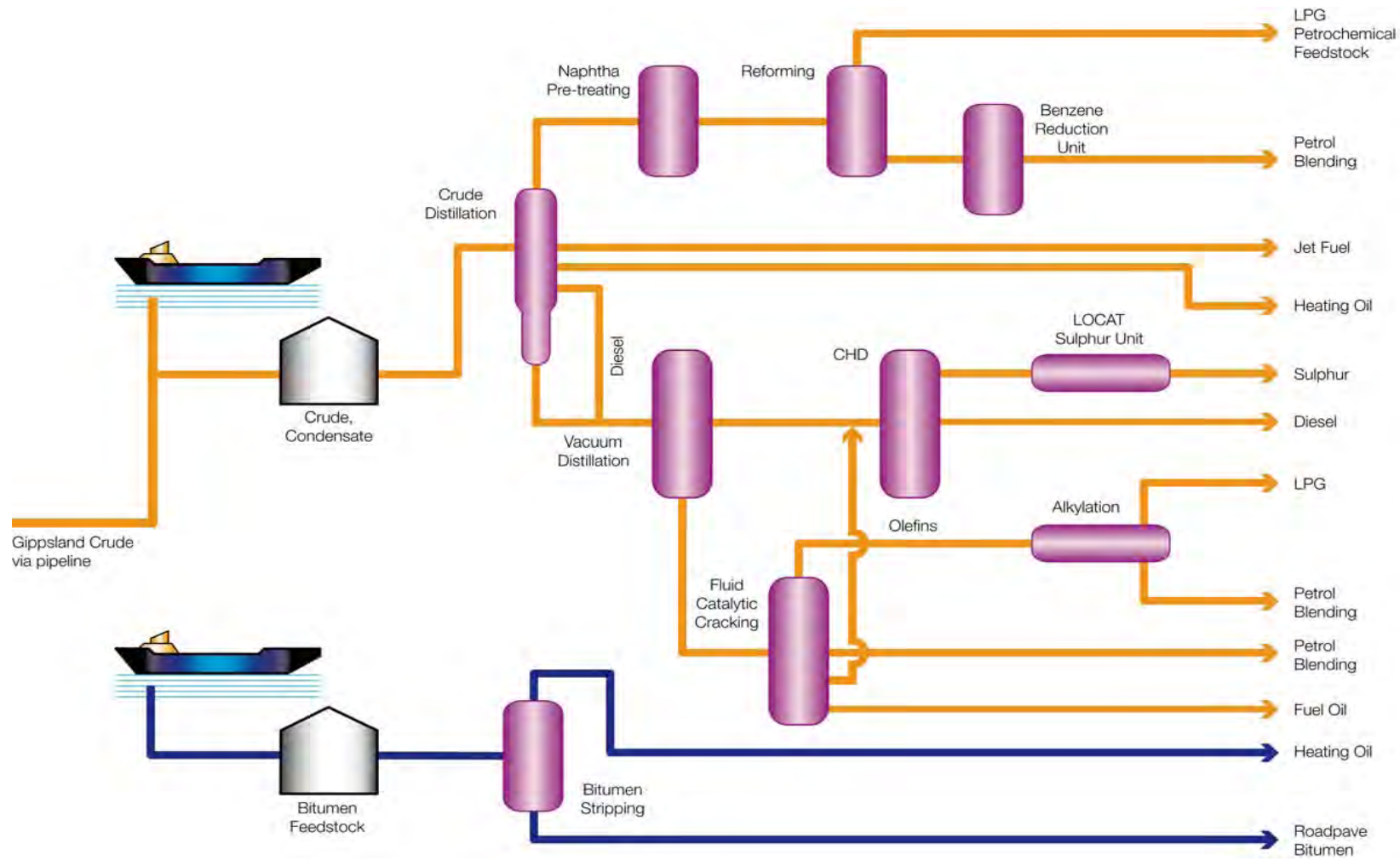

Appendix 2

Locality Plan - Refinery Area

Copyright Melway Publishing 2006. Reproduced from Melway Edition 34 with permission



LEGEND

- = CLOSELY-LOCATED MAJOR HAZARD FACILITY
- = MOBIL SITE
- = KNOWN POTENTIALLY HAZARDOUS INVENTORY
- = STAGING POINT FOR EMERGENCY SERVICES



Appendix 3

Locality Plan - Gellibrand Pier Area

Copyright Melway Publishing 2006. Reproduced from Melway Edition 34 with permission



LEGEND

-  = MOBIL SITE
-  = KNOWN POTENTIALLY HAZARDOUS INVENTORY
-  = STAGING POINT FOR EMERGENCY SERVICES

Glossary

ALARP	As Low As Reasonably Practicable; Measure of risk after implementation of control measures that eliminate or reduce risks to as low as practicable. Is applied consistent with the definition "so far as is practicable" used in the MHF Regulations.
CONSEQUENCE	The outcome of an event or incident expressed qualitatively or quantitatively, being loss, injury, disadvantage or gain.
CONTROL MEASURE	Measures for prevention or mitigation of a potential Major Incident by reducing the likelihood of a potential Major Incident and/or of reducing the magnitude or severity of the consequences.
HAZARD	Potential physical or chemical process, procedure or circumstance which could result in a potential Major Incident.
HAZID	Hazard Identification.
INCIDENT	A specific event or extended situation that has an undesirable and unintended impact on the safety or health of people, on property, or on the environment.
LIKELIHOOD	A qualitative description of probability and frequency.
LOCAL COMMUNITY	Local community includes members of the general public who reside in, or are in management and control of workplaces, or of places where persons gather for recreational, cultural, or sporting purpose, located in the surrounding area, whose health or safety could be adversely affected by a major incident at the facility.
MAJOR INCIDENT	An uncontrolled incident, including an emission, loss of containment, escape, fire, explosion or release of energy, that - a) involves Schedule 9 materials; and b) poses a serious and immediate risk to health and safety.
MHF	Major Hazard Facilities
MHF REGULATIONS	Occupational Health and Safety Regulations 2007
MITIGATION	Measures implemented in advance of an unplanned event aimed at decreasing or eliminating its impacts.
OIMS	Operations Integrity Management System.
RISK	A product of the likelihood of a potential Major Incident and the severity of associated consequences to persons both on site and offsite.
SAFETY CASE	Means a Safety Case prepared or revised under Part 5.2 of the Occupational Health and Safety Regulations 2007.

**SAFETY
ASSESSMENT**

A process of:
Potential Major Incident and hazard (cause) identification (HAZID) process
Risk Assessment
Control Measures analysis
ALAP Assessment

**SCHEDULE 9
MATERIALS**

Occupational Health and Safety Regulations 2007 Materials at Major Hazard facilities (and their threshold quantity).

SFAP

So Far As is Practicable.